

room temperature for 2 h. Extraction of this mixture with ether and water, followed by 10% aqueous HCl (to remove excess amine), afforded the *cis*-vinyl iodide free of the saturated iodide. After drying the ether with magnesium sulfate, concentration afforded product. Bulb-to-bulb distillation (90 °C (0.1 mmHg)) gave the product as a light yellow oil in 62% yield (which darkened upon standing): ¹H NMR δ 6.17 (m, 2 H), 3.63 (t, 2 H, *J* = 6.3 Hz), 2.15 (q, 2 H, *J* = 6.5 Hz), 1.80 (s, 1 H), 1.62-1.40 (m, 4 H); ¹³C NMR δ 141.02, 82.51, 62.63, 34.40, 32.14, 24.26; IR 3330, 1610, 1455, 1440, 1330, 1295, 1275, 1060, 985 cm⁻¹. HRMS: calcd for C₆H₁₁IO (-1), 98.0810; found, 99.0809. This compound did not exhibit a parent peak.

(*E*)-1-Trimethylstannyl-1-hexene. The vinyl stannane was prepared from (*E*)-1-iodo-1-hexene according to the general procedure³³ in 63% yield. The ¹H NMR was consistent with that described.¹²

(*Z*)-5-(*E*)-7-Dodecadien-1-ol. This compound was prepared by coupling (*Z*)-1-iodo-1-hexen-6-ol (355 mg, 1.57 mmol) with (*E*)-1-trimethylstannyl-1-hexene (468 mg, 1.73 mmol) using catalyst A (10 mg, 2.5 mol %) in DMF (4 mL) at room temperature. The reaction was worked up after 36 h in the usual way. The crude mixture was then rapidly chromatographed by MPLC (silica gel, 30% ethyl acetate in

hexanes) which produced an impure yellow oil. Careful MPLC of this oil (silica gel, 20% ethyl acetate in hexanes) gave the desired product in 73% yield: ¹H NMR δ 6.27 (m, 1 H), 5.93 (d of d appears as a triplet, 1 H, *J* = 10.9 Hz), 5.64 (d of t, 1 H, *J* = 15.0 and 7.0 Hz), 5.26 (d of t, 1 H, *J* = 10.8 and 7.6 Hz), 3.61 (t, 2 H, *J* = 6.5 Hz), 2.17 (m, 2 H), 2.07 (br q, 2 H, *J* = 6.7 Hz), 1.62-1.23 (m, 9 H), 0.87 (t, 3 H, *J* = 7.0 Hz); ¹³C NMR δ 134.94, 129.28, 129.18, 125.58, 62.79, 32.50, 32.40, 31.61, 27.38, 25.95, 22.25, 13.84; IR 3330, 1445, 1430, 1055, 980, 945 cm⁻¹. Spectra were consistent with literature values.³⁴ HRMS: calcd for C₁₂H₂₂O, 182.1671; found, 182.1670.

Acknowledgment. The authors gratefully acknowledge support for this research through Grant No. CHE-8305468 from the National Science Foundation. The palladium was obtained through the Johnson Matthey Inc. Metal Loan Program. High-resolution mass spectral determinations were performed by the Midwest Center for Mass Spectrometry, a National Science Foundation Regional Instrumentation Facility (Grant No. CHE-8211164).

(33) Matsubara, S.; Hibino, J. I.; Yoshimoto, M.; Koichiro, O.; Nozaki, H. *J. Organomet. Chem.* **1985**, 285, 163.

(34) Ando, T.; Kurotsu, Y.; Kaiya, M.; Uchiyama, A. *Agric. Biol. Chem.* **1985**, 49, 141.

Polymerization Reactions Involving the Side Chains of α-L-Amino Acids

Joachim Kohn and Robert Langer*

Contribution from the Department of Applied Biological Sciences, Massachusetts Institute of Technology, Cambridge, Massachusetts 02139. Received March 24, 1986

Abstract: The feasibility of polymerizing naturally occurring α-L-amino acids via their side chains by bonds other than the amide bond was investigated. Poly(Pal-Hpr-ester) [IUPAC name: poly[(1-palmitoyl-4,2-pyrrolidinediyl)carbonyloxy]] was obtained by melt transesterification of *N*-Pal-Hpr-Me [IUPAC name: *trans*-4-hydroxyl-1-palmitoyl-L-proline methyl ester] in the presence of aluminum isopropoxide as catalyst. *M_n* (8450) and *M_w* (15 500) were determined by gel permeation chromatography relative to polystyrene standards. The tyrosine dipeptide *Z*-Tyr-Tyr-Hex [IUPAC name: *N*-(*N*-benzyl-oxy-carbonyl-L-tyrosyl)-L-tyrosine hexyl ester] was cyanylated at the tyrosine side chain hydroxyl groups to yield *Z*-Tyr-Tyr-Hex-dicyanate [IUPAC name: *N*-[*N*-benzyl-oxy-carbonyl-3-(*p*-cyanatophenyl)-L-alanyl]-3-(*p*-cyanatophenyl)-L-alanine hexyl ester]. By solution polymerization of equimolar quantities of *Z*-Tyr-Tyr-Hex and *Z*-Tyr-Tyr-Hex-dicyanate in tetrahydrofuran, poly(*Z*-Tyr-Tyr-Hex-iminocarbonate) [IUPAC name: poly[oxyimidocarbonyloxy-*p*-phenylene[2-(hexyloxy-carbonyl)ethylene]imino[2-[1-(benzyloxy)formamido]-1-oxotrimethylene]-*p*-phenylene]] was obtained with *M_n* = 11 500 and *M_w* = 19 500. The synthesis of such "pseudopoly(amino acids)", which may be regarded as structural analogues of conventional poly(amino acids), may be of interest in enzymology, immunology, pharmacology, and biotechnology (biomaterials for medical applications).

Here we report on the synthesis of structurally new poly(amino acids) in which α-L-amino acids or dipeptides are polymerized by non-amide bonds (e.g., ester, iminocarbonate) involving the functional groups located on the amino acid side chains, rather than the amino acid termini.¹ Previously, Greenstein² attempted to use the sulfhydryl group of cysteine for the synthesis of a polysulfide by synthesizing cyclo(L-cysteinyl-L-cysteine) as monomer but failed to obtain a linear polymer due to preferential formation of a cyclic dimer. Later, Fasman³ attempted to convert poly(L-serine) to poly(L-serine-ester) by means of the N → O acyl shift of L-serine, but complete conversion of all amide bonds to ester bonds was not achieved. In contrast to the approach of Fasman, we attempted the direct polymerization of suitably

protected amino acids or dipeptides by polymerization reactions involving the functional groups located on the amino acid side chains.

We considered this approach since it would permit the synthesis of biomaterials (for drug delivery systems, sutures, artificial organs, etc.) which are derived from nontoxic metabolites (amino acids and dipeptides) while also having other desirable properties; e.g., the incorporation of an anhydride linkage into the polymer backbone could result in rapid biodegradability,⁴ an iminocarbonate bond may provide mechanical strength,⁵ and an ester bond may result in better film and fiber formation.⁶

Furthermore, pseudopoly(amino acids) can be either analogues (compound **5**) or true structural isomers (compound **2**) of conventional poly(amino acids). Therefore these materials would make new substrates in enzymology as well as facilitate studies

(1) By analogy with terminologies used in peptide chemistry (e.g., Spatola, A. F. *Chemistry and Biochemistry of Amino Acids, Peptides and Proteins*; Weinstein, B., Ed.; Marcel Dekker: New York, 1983; Vol. 7, pp 267-357) we used the name pseudopoly(amino acids) for these polymers to distinguish them from conventional poly(amino acids).

(2) Greenstein, J. P. *J. Biol. Chem.* **1937**, 118, 321-329.

(3) Fasman, G. D. *Science (Washington, D.C.)* **1960**, 131, 420-421.

(4) Leong, K. W.; Brott, B. C.; Langer, R. *J. Biomed. Mater. Res.* **1985**, 19, 941-955.

(5) Kohn, J.; Langer, R. *Biomaterials* **1986**, 7, 176-182.

(6) Goodman, I.; Rhys, J. A. *Polyesters*; American Elsevier: New York, 1965; Vol. 1, pp 38-77.

Scheme I

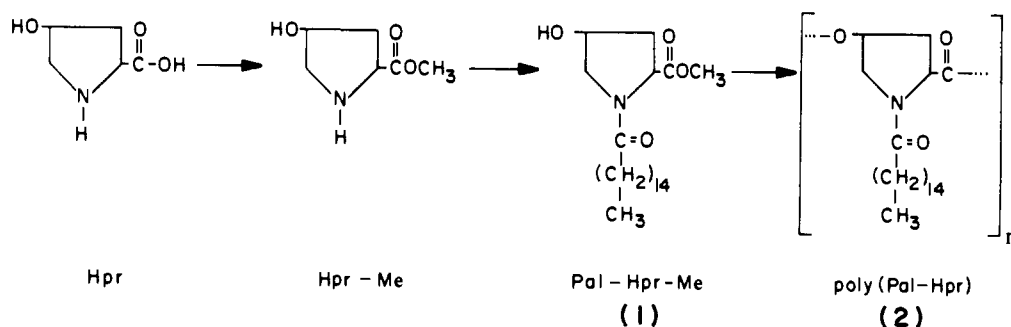

Scheme II

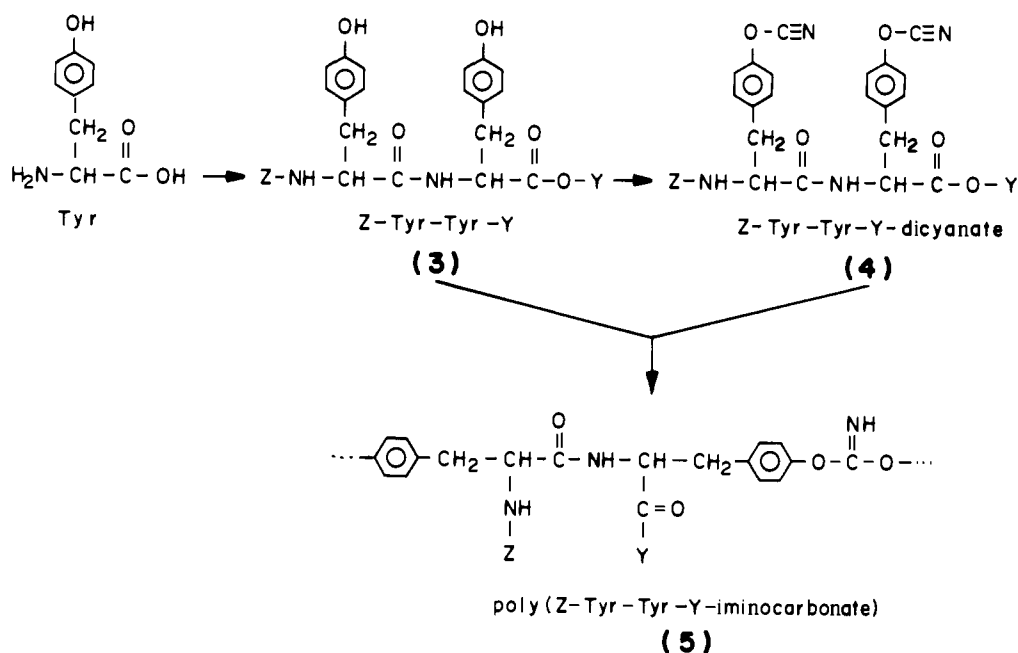

on the pharmacologic and immunologic activities of amino acid polymers as a function of changes in the linking bond of a given amino acid sequence, as opposed to the conventional approach of changing the primary amino acid sequence itself.

Results and Discussion

In the simplest case, a pseudopoly(amino acid) may be derived from a single amino acid as monomer. The synthesis of poly(Pal-Hpr-ester) (compound 2) serves to illustrate this approach (Scheme I). The monomer, Pal-Hpr-Me (compound 1), was prepared by conventional techniques of peptide chemistry. Several catalysts were screened for their efficacy in promoting the polymerization of 1 by melt transesterification. Strongly acidic compounds (e.g., *p*-toluenesulfonic acid) failed to show catalytic activity, while strongly basic compounds (e.g., potassium *tert*-butoxide) resulted in the rapid formation of colored side products. However, transition-metal salts (zinc or cadmium acetate) and Lewis acids (e.g., aluminum isopropoxide) were effective.

Best results were obtained by melt transesterification of Pal-Hpr-Me in the presence of aluminum isopropoxide (1% w/w) as catalyst at 140–180 °C for 20 h. Under these conditions, no evidence for side reactions at the tertiary amide bond was found by IR or ¹H NMR spectroscopies of the reaction product.

Poly(Pal-Hpr-ester) was obtained as a wax-like, white material that was insoluble in water, sparingly soluble in methanol, acetone, and DMF, and easily soluble in dioxane, benzene, hexane, ether, THF, and all chlorinated hydrocarbons. The polymer ($M_n = 8450$; $M_w = 15\,500$) had an intrinsic viscosity of 0.14 dL/g (chloroform, 25 °C). Differential scanning calorimetry gave a glass transition (T_g) at 55–60 °C and a melting range of 95–110 °C and showed that the polymer was thermally stable up to 320 °C (open pan). Polymer films obtained by solvent casting from methylene chloride

solutions were opaque and pliable.

Poly(Pal-Hpr-ester) is a structural isomer of a conventional poly(amino acid) derived from O-acylated hydroxy-L-proline. Since *trans*-4-hydroxy-L-proline is a constituent of gelatin, collagen, and other proteins,^{7,8} while palmitic acid is a major constituent of body fat,⁹ poly(Pal-Hpr-ester) has the advantage of being exclusively derived from natural metabolites. Such polymers often exhibit minimum toxicity,^{10,11} which is an important prerequisite when polymeric materials are considered for medical applications such as sutures, implantable devices, drug delivery, etc.

Dipeptides can also be employed as monomers. Upon polymerization via the amino acid side chains, polymers are obtained whose backbone consists of amide bonds strictly alternating with non-amide linkages (Scheme II). The feasibility of this concept was illustrated by the synthesis of a poly(iminocarbonate amide) from a dityrosine peptide. First Z-Tyr-Tyr-Hex (compound 3) was obtained. Then the phenolic hydroxyl groups of the tyrosine side chains were cyanylated by cyanogen bromide. The structure of the corresponding dicyanated peptide (compound 4) was confirmed by elemental analysis and IR spectroscopy which revealed the characteristic absorption of aromatic cyanate esters.^{12,13} Compound 4 was stable enough to be purified by recrystallization

(7) Mauger, A. B. *Chemistry and Biochemistry of Amino Acids, Peptides and Proteins*; Weinstein, B., Ed.; Marcel Dekker: New York, 1977; Vol. 4, pp 179–240.

(8) Greenstein, J. P.; Winitz, M. *Chemistry of the Amino Acids*; John Wiley: New York, 1961; Vol. 3, pp 2018–2042.

(9) Lehninger, A. L. *Biochemistry*; Worth: New York, 1975; p 280.

(10) Williams, D. F. *J. Mater. Sci.* **1982**, *17*, 1233–1246.

(11) Pitt, C. G.; Schindler, A. *Controlled Drug Delivery—Basic Concepts*; Bruck, S. D., Ed.; CRC: Boca Raton, FL, 1983; Vol. 1, pp 53–80.

(12) Groving, N.; Holm, A. *Acta Chem. Scand.* **1965**, *19*, 443.

(13) Reich, P.; Martin, D. *Chem. Ber.* **1965**, *98*, 2063.

and stored at $-15\text{ }^{\circ}\text{C}$ for over 1 year without noticeable decomposition. Due to the versatility of cyanate esters as intermediates in organic synthesis, cyanylated peptides may be of interest in protein chemistry.¹⁴ The reaction of equimolar quantities of **3** and **4** in peroxide-free tetrahydrofuran in the presence of potassium *tert*-butoxide (0.1% w/w) as catalyst at $50\text{ }^{\circ}\text{C}$ resulted in polymerization due to the facile formation of the iminocarbonate linkage. The progress of the polymerization could be followed by quantitative determination of the remaining cyanate end groups.¹⁵ The resulting polymer (compound **5**) was a slightly yellowish, brittle solid. Its structure was ascertained by IR, ^1H NMR, and elemental analysis.

Poly(Z-Tyr-Tyr-Hex-iminocarbonate) was obtained as a slightly tinged powder that was insoluble in water, alcohol, acetone, aromatic hydrocarbons, ether, and hexane but soluble in chlorinated hydrocarbons (except CCl_4), THF, DMF, and Me_2SO . The polymer ($M_n = 11\,500$; $M_w = 19\,500$) had an intrinsic viscosity of 0.27 dL/g (DMF, $25\text{ }^{\circ}\text{C}$). Differential scanning calorimetry showed a glass transition (T_g) at $75\text{--}85\text{ }^{\circ}\text{C}$, a melting range of $130\text{--}140\text{ }^{\circ}\text{C}$, and thermal stability (open pan) up to $140\text{ }^{\circ}\text{C}$. Polymer films, obtained by solvent casting from solutions in methylene chloride, were transparent and brittle.

The above examples indicate that by using linking bonds other than the amide bond, structurally modified pseudopoly(amino acids) can be obtained. The biological and pharmacological properties of compounds **2** and **5** are presently under investigation. The approach of involving the amino acid side chains in polymerization reactions should make it possible to synthesize a variety of structurally unique pseudopoly(amino acids).

Experimental Section

General Methods. All solvents were analytical grade. *trans*-4-Hydroxyl-L-proline was obtained from Sigma Chemical Co., St. Louis, MO; thionyl chloride (purity $> 99\%$) was from Fluka A.G. (Switzerland); and 1-hexanol, hexadecanoyl chloride, aluminum isopropoxide, dicyclohexylcarbodiimide (DCC), zinc acetate and cadmium acetate were from Aldrich Chemical Co., Milwaukee, WI. L-Tyrosine and *N*-benzyloxycarbonyl-L-tyrosine were from Chemical Dynamics Corp., South Plainfield, NJ. Elemental analyses were performed by Galbraith Laboratories, Knoxville, TN.

Melting points were recorded on a Fisher-Johns melting point apparatus.

Optical rotations were measured by a SR6 polarimeter (Polyscience Corp.) at the sodium D line (589 nm) in a 200-mm measuring tube at $20\text{ }^{\circ}\text{C}$.

IR spectroscopy was performed on a Perkin-Elmer Series 1420 dispersive spectrophotometer.

Thermal analysis of polymers was done by "differential scanning calorimetry" (DSC), employing a Perkin-Elmer DSC 2 differential scanning calorimeter system. The average sample size was 10 mg, and a heating rate of $20\text{ }^{\circ}\text{C}/\text{min}$ was employed.

The molecular weight of polymers was determined relative to polystyrene standards in chloroform solutions (10 mg/mL) by gel permeation chromatography on a Perkin-Elmer chromatograph equipped with a LKB-2140 diode array multiple-wavelength UV detector. Two Perkin-Elmer PL-gel ($10\text{-}\mu\text{m}$) columns (exclusion limits: $500\text{--}750\,000$), connected in series, were used. The flow rate was $1.5\text{ mL}/\text{min}$. Alternatively, a Knauer (Germany) vapor pressure osmometer was used (chloroform, $45\text{ }^{\circ}\text{C}$).

Polymer Characterizations. Determinations of solubility, melting range, viscosity, and thermal stability were performed according to Collins et al.¹⁶

Syntheses

***trans*-4-Hydroxy-L-proline methyl ester hydrochloride (Hpr-Me-HCl)** was prepared by the thionyl chloride technique:¹⁷ mp $171\text{--}172\text{ }^{\circ}\text{C}$ [lit.¹⁷ mp $169\text{--}170\text{ }^{\circ}\text{C}$ dec]; $[\alpha]_D^{20} -27.3^{\circ}$ (*c* 5, H_2O).

***trans*-4-Hydroxy-1-palmitoyl-L-proline Methyl Ester (Pal-Hpr-Me, **1**).** Hpr-Me-HCl (0.08 mol, 14.8 g) was dissolved in water (100 mL) and

placed in a three-necked flask; ethyl acetate (250 mL) was added, and the mixture was cooled to $5\text{ }^{\circ}\text{C}$. With stirring, KHCO_3 (0.24 mol, 24 g) was added to the flask. A solution of hexadecanoyl chloride (0.088 mol, 21.8 g) in ethyl acetate (200 mL) was added with vigorous stirring at a rate of $8\text{ mL}/\text{min}$. Stirring was continued for 30 min. The aqueous phase was discarded. The organic phase was washed with 0.1 N HCl (100 mL) and a saturated NaCl solution (100 mL), dried over anhydrous MgSO_4 , treated with activated charcoal (1 g), and filtered. The clear filtrate was evaporated to dryness under reduced pressure ($100\text{ mmHg}/40\text{ }^{\circ}\text{C}$). Pal-Hpr-Me was obtained as a white, crystalline solid; yield 24 g (78%). The crude material was purified by flash chromatography in ethyl acetate as solvent, followed by recrystallization from petroleum ether (boiling range $40\text{--}60\text{ }^{\circ}\text{C}$). Recrystallized Pal-Hpr-Me was obtained as lustrous crystals: mp $63\text{--}64\text{ }^{\circ}\text{C}$; $[\alpha]_D^{20} -37.7^{\circ}$ (*c* 5, ethyl acetate); IR (tetrachloroethane, cm^{-1}) ν_{OH} 3596 (m), ν_{CH} 2922 (s), 2856 (m), $\nu_{\text{C=O}}$ 1742 (s), ν_{CN} 1642 (s), 1435 (s), 1080 (w).

Anal. Calcd for $\text{C}_{22}\text{H}_{41}\text{NO}_4$: C, 68.89; H, 10.77; N, 3.65. Found: C, 68.99; H, 10.55; N, 3.58.

Poly[(1-palmitoyl-4,2-pyrrolidinediyl)carboxyloxy] (2**).** A magnetic stir bar was placed into a melt polymerization tube. The tube was charged with recrystallized Pal-Hpr-Me (3.0 g) and finely powdered aluminum isopropoxide (30 mg). The tube was first heated under vacuum to $140\text{ }^{\circ}\text{C}$ for 4 h and then to $180\text{ }^{\circ}\text{C}$ for an additional 16 h. The evolution of methanol was observed, and the reaction mixture became increasingly viscous. When stirring was no longer possible, dry argon was bubbled through the melt. After 20 h a wax-like material was obtained. Purification: the polymer was dissolved in THF (0.5 g/mL) and precipitated by addition of 2-propanol.

Compound **2**: IR (film on NaCl, cm^{-1}) ν_{CH} 2920 (s), 2850 (m), $\nu_{\text{C=O}}$ 1742 (s), ν_{amide} 1648 (s), 1422 (m), $\nu_{\text{C-O-C}}$ 1179 (s), 1059 (m), 722 (w); $^1\text{H NMR}$ (CDCl_3) δ 0.89 (3 H, t, CH_3), 1.25 (24 H, s, 12CH_2), 1.61 (2 H, m, CH_2), 2.28 (4 H, br m, 2CH_2), 3.79 (2 H, br m, CH_2), 4.41 (H, t, CH), 5.42 (H, br m, CH); molecular weight (relative to polystyrene standards by GPC) $M_n = 8450$, $M_w = 15\,500$, DP = $24\text{--}25$.

Anal. Calcd for $\text{C}_{21}\text{H}_{37}\text{NO}_3$: C, 71.75; H, 10.61; N, 3.98. Found: C, 71.57; H, 10.86; N, 3.96.

L-Tyrosine Hexyl Ester Hydrochloride (Tyr-Hex-HCl). Tyr-Hex-HCl was prepared by a modified version of the thionyl chloride technique.¹⁷ To 1-hexanol (75 mL) at $0\text{ }^{\circ}\text{C}$, thionyl chloride (6.55 g , 0.055 mol) and L-tyrosine (9.05 g , 0.05 mol) were added. The resulting suspension was stirred at $70\text{ }^{\circ}\text{C}$ for 12 h. As the mixture cooled, Tyr-Hex-HCl precipitated. Precipitation was brought to completion by the addition of ether (350 mL). The precipitate was collected, washed with ether ($3 \times 100\text{ mL}$), and dried: yield 94% ; mp $162\text{--}164\text{ }^{\circ}\text{C}$.

Anal. Calcd for $\text{C}_{15}\text{H}_{24}\text{ClNO}_3$: C, 59.69; H, 8.02; Cl, 11.75; N, 4.64. Found: C, 59.83; H, 8.08; Cl, 11.80; N, 4.58.

***N*-(*N*-Benzyloxycarbonyl-L-tyrosyl)-L-tyrosine Hexyl Ester (Z-Tyr-Tyr-Hex, **3**).** Z-Tyr-Tyr-Hex was prepared from Z-Tyr and Tyr-Hex-HCl by the carbodiimide coupling technique.¹⁸ The yield of crude product was 89% . The crude material was purified by flash chromatography using hexane-ethyl acetate-methanol (50:95:5) as the mobile phase, followed by recrystallization. One gram was dissolved at $50\text{ }^{\circ}\text{C}$ in 10 mL of ethyl acetate-methanol (95:5). Then 20 mL of hexane was added. After the mixture stood for 12 h at $25\text{ }^{\circ}\text{C}$, the recrystallized material was collected and dried in vacuo: mp $154\text{--}155\text{ }^{\circ}\text{C}$; $[\alpha]_D^{20} +13.8^{\circ}$ (*c* 5, ethyl acetate); IR (tetrachloroethane, cm^{-1}) ν_{OH} 3580 (m), ν_{NH} 3409 (m), ν_{CH} 2957 (m), 2930 (m), 2859 (w), $\nu_{\text{C=O}}$ 1727 (s), ν_{amide} 1675 (s), 1612 (m), 1595 (weak), 1512 (s), 1466 (w), 1453 (w), 1441 (w), 1395 (w), 1113 , 1103 (w, doublet), the regions obscured by solvent absorptions (cm^{-1}) were $3040\text{--}2960$, $1300\text{--}1170$, $1040\text{--}990$, <860 .

Anal. Calcd for $\text{C}_{32}\text{H}_{38}\text{N}_2\text{O}_7$: C, 68.31; H, 6.81; N, 4.98. Found: C, 68.35; H, 6.74; N, 5.01.

Z-Tyr-Tyr-Hex-Dicyanate (4**).** The cyanylation procedure of Grigat and Pütter¹⁹ was extensively modified: Z-Tyr-Tyr-Hex (5 mmol , 2.81 g) and triethylamine (16 mmol , 2.2 mL) were dissolved in 15 mL of THF (solution A). Cyanogen bromide (19 mmol , 2.0 g) was dissolved in 20 mL of THF (solution B). Under anhydrous conditions, solution B was placed into a three-necked flask and cooled to $-10\text{ }^{\circ}\text{C}$. Solution A was placed into a dropping funnel and added to the reaction flask with vigorous stirring at a rate of $2\text{ mL}/\text{min}$, with the reaction temperature being kept below $0\text{ }^{\circ}\text{C}$. A precipitate of $\text{Et}_3\text{N}\cdot\text{HCl}$ formed. Stirring was continued for an additional 15 min. During this time the reaction mixture was gradually warmed to $+10\text{ }^{\circ}\text{C}$. The precipitate was removed by filtration and washed with THF (30 mL). Combined filtrate and washings were cooled to $0\text{ }^{\circ}\text{C}$, and ice-cold water (400 mL) was added with vigorous stirring, resulting in a white precipitate of crude dicyanate. The crude product was collected, washed with acetone-water (3:7), and

(14) Powers, J. C.; Tuhy, P. M.; Witter, F. *Biochim. Biophys. Acta* **1976**, *445*, 426-436.

(15) Kohn, J.; Albert, E. C.; Langer, R. *Anal. Chem.* **1986**, *58*, 3184-3188.

(16) Collins, E. A.; Bares, J.; Billmeyer, F. W. *Experiments in Polymer Science*; Wiley: New York, 1973; Chapter 6, pp 99-115.

(17) Greenstein, J. P.; Winitz, M. *Chemistry of the Amino Acids*; Wiley: New York, 1961; Vol. 2, procedure 10-50, p 927.

(18) König, W.; Geiger, R. *Chem. Ber.* **1970**, *103*, 788-798.

(19) Grigat, E.; Pütter, R. *Chem. Ber.* **1964**, *97*, 3012-3017.

dried. Crude product was dissolved in boiling 2-propanol at a concentration of 0.02 g/mL and was allowed to cool slowly. Fine needles precipitated: yield 78%; mp 152–154 °C; IR (tetrachloroethane, cm^{-1}) ν_{NH} 3412 (m), ν_{CH} 2957 (m), 2927 (m), 2859 (m), ν_{OCN} 2279 (s), 2262 (s), 2239 (s), $\nu_{\text{C=O}}$ 1725 (br s), ν_{amide} 1678 (s), 1603 (m), 1501 (s).

Anal. Calcd for $\text{C}_{34}\text{H}_{36}\text{N}_4\text{O}_7$: C, 66.65; H, 5.92; N, 9.14. Found: C, 66.60; H, 6.00; N, 9.09.

Poly(Z-Tyr-Tyr-Hex-Iminocarbonate) (5). A solution of equimolar quantities of Z-Tyr-Tyr-Hex and Z-Tyr-Tyr-Hex-dicyanate was prepared in THF (0.2 mmol/mL) and placed in a sealed flask under an atmosphere of argon at 50 °C. With stirring, 0.1% (w/w) of potassium *tert*-butoxide (0.5 M in 2-methyl-2-propanol) was injected into the reaction mixture. The solution became viscous, and after 90 min polymer precipitated. After 4 h the polymer was completely precipitated by addition of acetone, collected on a Buchner funnel, washed with acetone, and dried in vacuo; yield 90–95%. The progress of the polymerization reaction was followed by end group analysis employing the pyridine-barbituric acid color reaction for determination of cyanate esters.¹⁵

Compound 5: IR (tetrachloroethane, cm^{-1}) ν_{NH} 3412 (m), 3332 (w), ν_{CH} 2958 (m), 2928 (m), 2859 (w), $\nu_{\text{C=O}}$ 1726 (br s), ν_{amide} 1676 (br s, shoulder at 1690 (iminocarbonate)), ν (aromatic ring) 1603 (w), 1502 (w), 1310 (br s), 1056 (br m), the regions obscured by solvent absorptions (cm^{-1}) were 3040–2960, 1300–1170, 1040–990, <860; $^1\text{H NMR}$ (CD_2Cl_2) δ 0.88 (3 H, t, CH_3), 1.27 (6 H, m narrow, 3CH_2), 1.56 (2 H, br m, CH_2), 3.00 (4 H, br m, 2CH_2), 4.05 (2H, br m, CH_2), 4.42 (1 H, br m, CH), 4.78 (1 H, br m, CH), 5.05 (2 H, s, CH_2), 5.55 (2 H, br m, 2 NH_{amide}), 6.57 (1 H, br s, NH_{imino}), 7.08 (8 H, m, two 1,4-Ph), 7.31 (5 H, m, Ph); molecular weight (GPC and vapor pressure osmometry in chloroform) $M_n = 11\,500$, $M_w = 19\,500$, DP = 19–20.

Anal. Calcd for $\text{C}_{33}\text{H}_{37}\text{N}_3\text{O}_7$: C, 67.45; H, 6.35; N, 7.15. Found: C, 66.81; H, 6.57; N, 7.10.

Acknowledgment. We thank Professor G. Wnek for helping with the interpretation of the spectra and E. C. Albert, D. Kline, and H. Yu for their assistance. This work was supported by NIH Grant GM 26698.

Thermal Reorganization of Two Pyramidalized Alkenes by Reverse Vinylcyclopropane Rearrangements

Tyze-Kuan Yin,[†] Juliusz G. Radziszewski,[‡] George E. Renzoni,[†] John W. Downing,[‡] Josef Michl,[‡] and Weston Thatcher Borden*[†]

Contribution from the Department of Chemistry, University of Washington, Seattle, Washington 98195, and the Department of Chemistry, University of Utah, Salt Lake City, Utah 84112. Received May 2, 1986. Revised Manuscript Received October 20, 1986

Abstract: 2,6-Dimethylenebicyclo[2.2.*n*]alkanes **5** and **6** are formed, respectively, by flash vacuum pyrolysis of the β -lactone precursors (**1** and **2**) of pyramidalized alkenes **3** and **4** at high temperatures. The mechanism by which **5** and **6** are formed has been elucidated by isolation of an intermediate (**8**) in the transformation of **4** to **6**. The sensitivity of **8** to acid suggests that its rearrangement to **6** may be surface catalyzed. The formation of **8** from **4**, which is the reverse of the usual vinylcyclopropane rearrangement, can also be induced photochemically. From the thermal isomerization of **4** to **8** it is possible to establish a lower limit to the strain energy in **4** that is attributable to the presence of the pyramidalized double bond. This value is compared to the olefin strain energy computed for **4** by MM2 and by MNDO calculations.

We have previously reported¹ that flash vacuum pyrolysis (FVP) of β -lactone **1**² at temperatures above 550 °C leads to formation of small amounts of the dimer of pyramidalized alkene **3** but that the major product isolated is 2,6-dimethylenebicyclo[2.2.1]heptane (**5**). Herein, we describe the thermal chemistry of the homologous

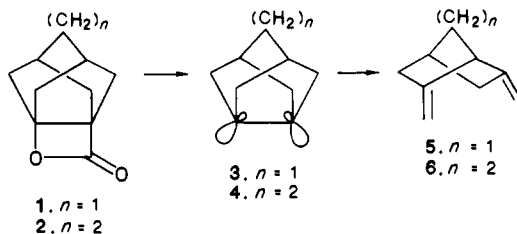

alkene **4**,^{2,3} which bears on the mechanism by which **5** is formed from **3**. We also show that from this data a lower limit can be placed on the strain caused by the presence of the pyramidalized double bond in **4**.

Results

The β -lactone precursor **2** of alkene **4** is 50% decarboxylated on FVP at 410 °C. At this pyrolysis temperature, IR analysis of the pyrolysate, trapped at 10 K, shows the sole products to be **4** and CO_2 .³ The only product detected after warm-up is the “2 + 2” dimer of **4**.²

However, as the pyrolysis temperature is raised, formation of an isomer of **4** is observed.³ GLC analysis of the pyrolysate shows that at 440 °C the dimer constitutes about 90% by weight of the product mixture and the new hydrocarbon 10%, but at 530 °C the new hydrocarbon is the major product, and the dimer of **4** comprises only about 10% of the product mixture.

Interestingly, this isomer of **4** is itself thermally labile, undergoing rearrangement to 2,6-dimethylenebicyclo[2.2.2]octane (**6**). When **2** is pyrolyzed, small amounts of **6** can be detected at 480 °C, and at 530 °C **6** comprises about 40% of the product mixture. That the isomer formed from **4** can act as the direct precursor of **6** was shown by partial rearrangement of the former to the latter on FVP at 500 °C.

The rearrangement of **4** to the thermally labile isomer was established unequivocally in the following manner. β -Lactone **2** was pyrolyzed under conditions where its conversion to **4** was about 90% complete, and then the pyrolysate was passed through a second hot zone. GLC analysis of the product mixture showed that passage through the second hot zone resulted in a 40% decrease in the amount of the dimer formed from **4** and a corresponding increase in the combined amounts of the thermally labile isomer and its rearrangement product (**6**).

(1) Renzoni, G. E.; Yin, T.-K.; Borden, W. T. *J. Am. Chem. Soc.* **1986**, *108*, 7121.

(2) Renzoni, G. E.; Yin, T. K.; Miyake, F.; Borden, W. T. *Tetrahedron* **1986**, *42*, 1581.

(3) Radziszewski, J. G.; Yin, T.-K.; Miyake, F.; Renzoni, G. E.; Borden, W. T.; Michl, J. *J. Am. Chem. Soc.* **1986**, *108*, 3544.

[†]University of Washington.

[‡]University of Utah. Present address: Department of Chemistry, University of Texas, Austin, Texas 78712.